

3-5 PSI
PRESSURE SWITCH
TIG31055

7-10 PSI
PRESSURE SWITCH
TIG31056

RELAY BOX JD331121
ON CHASSIS RAIL

Bendix EC60 frame
X1 (grey) connector PIN 9
(ECU power)

Bendix EC60 FRAME terminal p/n
DEUTSCH #0462-201-16141 (SOLID)
DEUTSCH #1062-16-06 (STAMPED)
NAV #1680205C1

Bendix EC60 frame
X1 (grey) connector PIN 10
(ground during wheel slip)

SPEED SIGNAL ALLISON GEN 4 PIN 25

Allison GEN4 terminal p/n
MOLEX #33001-1004
NAV # 3606047C1

DO NOT CONNECT—PNK 18G

DO NOT CONNECT—PNK 18G

TO IGNITION — RED 18G

TELMA AIR FOOT CONTROL WIRING
BENDIX EC-60 FRAME ABS
12oct09

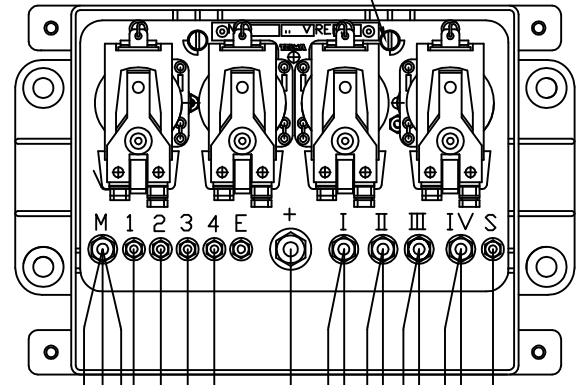
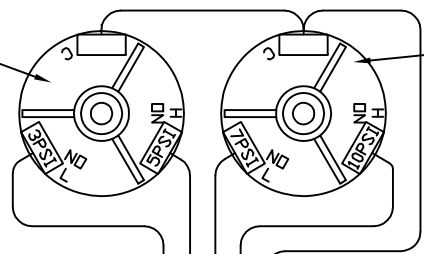

ABS CONTROL

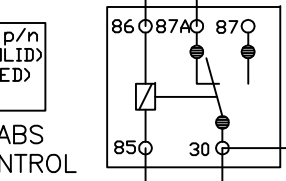

ABS INTERFACE
CONNECTOR FRONT VIEW
JC241105 ALLISON WORLD

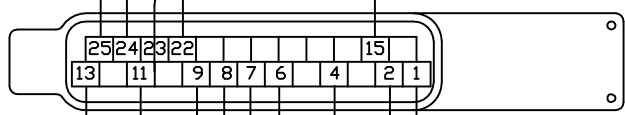

DO NOT
CONNECT

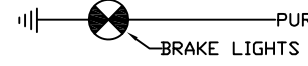

LIGHT
BAR
DISPLAY
TIG11010

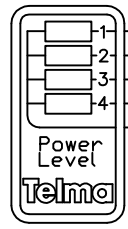

BATTERY
DISCONNECT
SWITCH

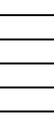
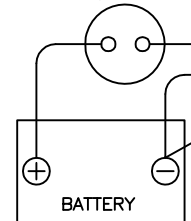

BATT.(+) RED 2/0
BATT.(-) BLK 2/0

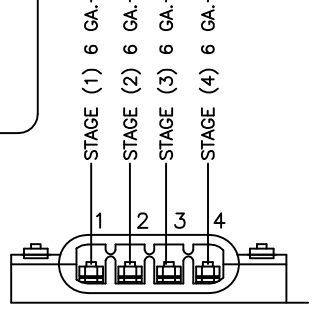

POWER CONNECTIONS



Service Data

SD-13-4863

Bendix® EC-60™ ABS / ATC Controllers (Standard & Premium Models)

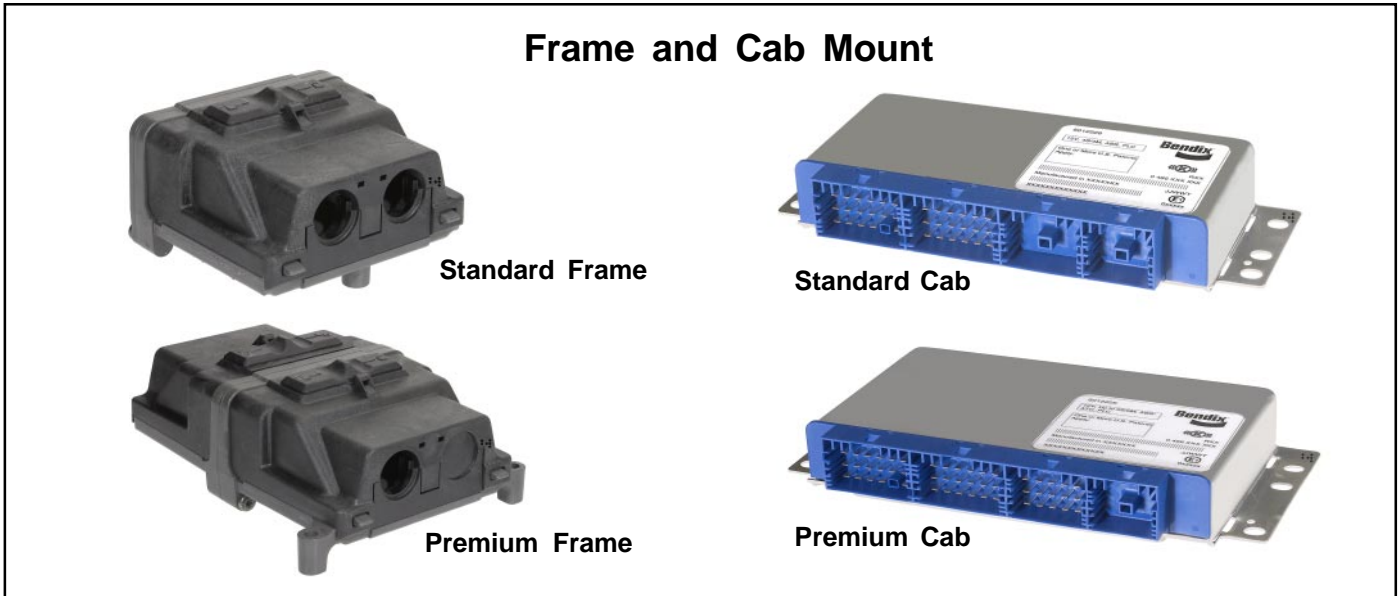

FIGURE 1 - EC-60™ CONTROLLERS

INTRODUCTION

Bendix® EC-60™ controllers are members of a family of electronic **Antilock Braking System (ABS)** devices designed to help improve the braking characteristics of air braked vehicles - including heavy and medium duty buses, trucks, and tractors. ABS controllers are also known as **Electronic Control Units (ECUs)**.

Bendix ABS uses wheel speed sensors, ABS modulator valves, and an ECU to control either four or six wheels of a vehicle. By monitoring individual wheel turning motion during braking, and adjusting or pulsing the brake pressure at each wheel, the EC-60™ controller is able to optimize slip between the tire and the road surface. When excessive wheel slip, or wheel lock-up, is detected, the EC-60™ controller will activate the Pressure Modulator Valves to simulate a driver pumping the brakes. However, the EC-60™ controller is able to pump the brakes on individual wheels (or pairs of wheels), independently, and with greater speed and accuracy than a driver.

In addition to the ABS function, premium models of the EC-60™ controller provide an **Automatic Traction Control (ATC)** feature. Bendix ATC can improve vehicle traction during acceleration, and lateral stability while driving through curves. ATC utilizes **Engine Torque Limiting (ETL)** where the ECU communicates with the engine's controller and/or **Differential Braking (DB)** where individual wheel brake applications are used to improve vehicle traction.

Premium EC-60™ controllers have a drag torque control feature which reduces driven-axle wheel slip (due to driveline inertia) by communicating with the engine's controller and increasing the engine torque.

TABLE OF CONTENTS	PAGE
General System Information	
Introduction	1
Components	2
ECU Mounting	2
EC-60™ Controller Hardware Configurations	2
EC-60™ Controllers with PLC	3
EC-60™ Controller Inputs	3
ABS Off-Road Switch and Indicator Lamp	4
EC-60™ Controller Outputs	4
Power-Up Sequence	5
ABS Operation	6
ATC Operation	7
Dynamometer Test Mode	8
Automatic Tire Size Calibration	8
ABS Partial Shutdown	9
System Reconfiguration	
EC-60™ Controller System Reconfiguration	10
Troubleshooting	
General	11
Diagnostic Trouble Codes	12
Using Hand-Held or PC-based Diagnostics	13
Diagnostic Trouble Code Troubleshooting Index	16
Trouble Code Tests	18 - 27
Connector and Harnesses	28-31
Wiring	32-34
Wiring Schematics	28-31
Glossary	41

EC-60™ Controller Wire Harness Connector
Part Numbers and Pin Assignments:
STANDARD FRAME



Standard Frame EC-60™ Controller

Standard frame models utilize two Deutsch connectors for wire harness connections.

Connector Designation	Number of Contacts	Deutsch Part Number
X1	15	DT16-15SA-K003
X2	18	DT16-18SB-K004

Standard Frame X1 Connector Pin Assignments

Pin	Designation	Pin	Designation	Pin	Designation
1	J1587 (B)	6	J1939 High	11	Trailer ABS WL
2	J1939 Low	7	WSS SA Left (-)	12	ABS WL
3	WSS SA Left (+)	8	WSS SA Right (-)	13	Not Used
4	WSS SA Right (+)	9	Ignition	14	Battery
5	J1587 (A)	10	Retarder	15	Ground

Standard Frame X2 Connector Pin Assignments

Pin	Designation	Pin	Designation	Pin	Designation
1	WSS DA Left (+)	7	PMV SA Left HLD	13	PMV SA Left CMN
2	WSS DA Left (-)	8	PMV SA Left REL	14	PMV SA Right CMN
3	WSS DA Right (+)	9	PMV SA Right HLD	15	PMV DA Left CMN
4	WSS DA Right (-)	10	PMV SA Right REL	16	PMV DA Right CMN
5	Not Used	11	PMV DA Left HLD	17	PMV DA Right HLD
6	Not Used	12	PMV DA Left REL	18	PMV DA Right REL

**EC-60™ Controller Wire Harness Connector
Part Numbers and Pin Assignments:**

PREMIUM FRAME

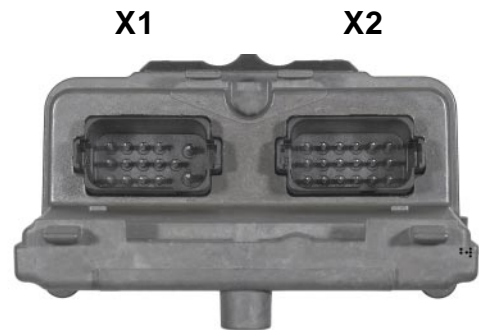
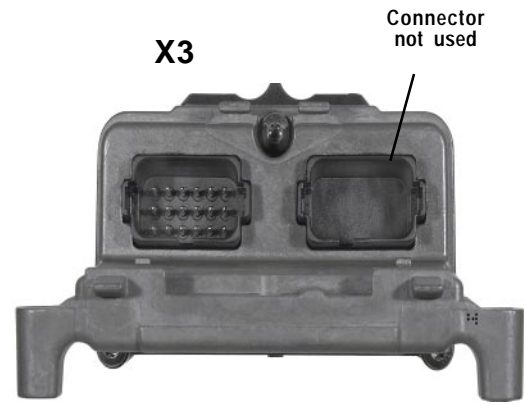

Premium Frame Model EC-60™ Controller
Premium frame models utilize three Deutsch connectors for wire harness connections.

Connector Designation	Number of Contacts	Deutsch Part Number
X1	15	DT16-15SA-K003
X2	18	DT16-18SB-K004
X3	18	DT16-18SC-K004

Premium Frame X1 Connector Pin Assignments

Pin	Designation	Pin	Designation	Pin	Designation
1	J1587 (B)	6	J1939 High	11	Trailer ABS WL
2	J1939 Low	7	WSS SA Left (-)	12	ABS WL
3	WSS SA Left (+)	8	WSS SA Right (-)	13	ATC Lamp/ATC ORS
4	WSS SA Right (+)	9	Ignition	14	Battery
5	J1587 (A)	10	Retarder	15	Ground

Premium Frame X2 Connector Pin Assignments

Pin	Designation	Pin	Designation	Pin	Designation
1	WSS DA Left (+)	7	PMV SA Left HLD	13	PMV SA Left CMN
2	WSS DA Left (-)	8	PMV SA Left REL	14	PMV SA Right CMN
3	WSS DA Right (+)	9	PMV SA Right HLD	15	PMV DA Left CMN
4	WSS DA Right (-)	10	PMV SA Right REL	16	PMV DA Right CMN
5	SLS	11	PMV DA Left HLD	17	PMV DA Right HLD
6	ABS ORS	12	PMV DA Left REL	18	PMV DA Right REL

Premium Frame X3 Connector Pin Assignments

Pin	Designation	Pin	Designation	Pin	Designation
1	Reserved	7	TCV	13	TCV CMN
2	Not Used	8	Diff. Lock SOL ¹	14	Diff. Lock SOL CMN ¹
3	WSS AA Left (+)	9	PMV AA Left HLD	15	PMV AA Left CMN
4	WSS AA Left (-)	10	PMV AA Left REL	16	PMV AA Right CMN
5	WSS AA Right (+)	11	Reserved	17	PMV AA Right HLD
6	WSS AA Right (-)	12	Reserved	18	PMV AA Right REL

¹AWD vehicles only. (AWD Transfer Case)

Frame-mount ECU: Looking into wire harness connector

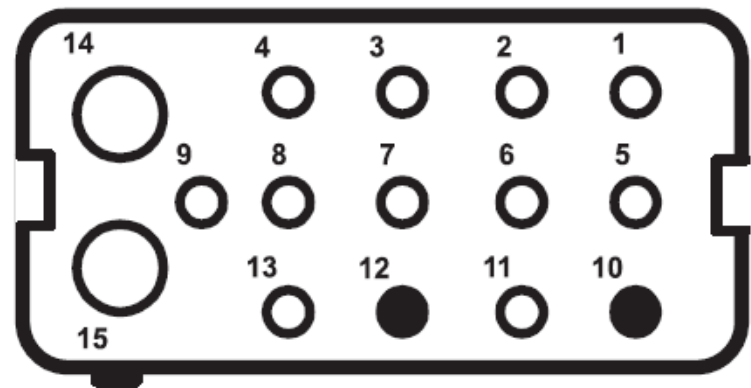

X 1

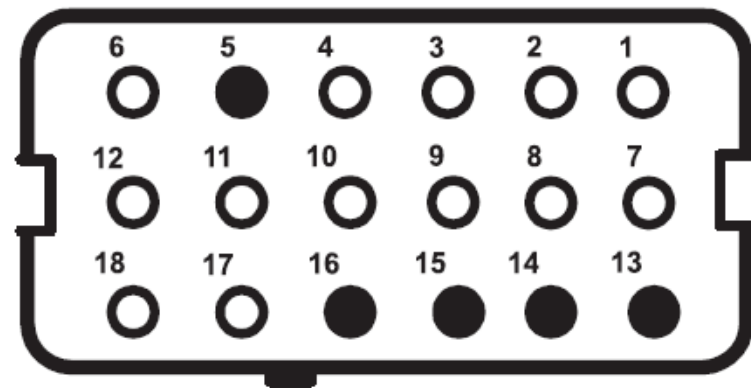

X 2

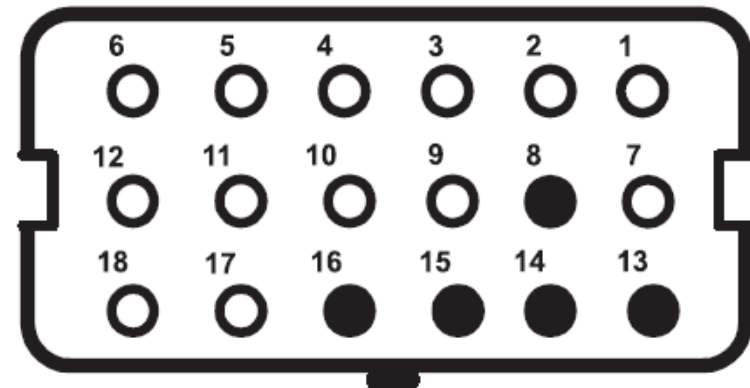

X 3

Troubleshooting: Standard Frame Wiring Schematic (4S/4M)

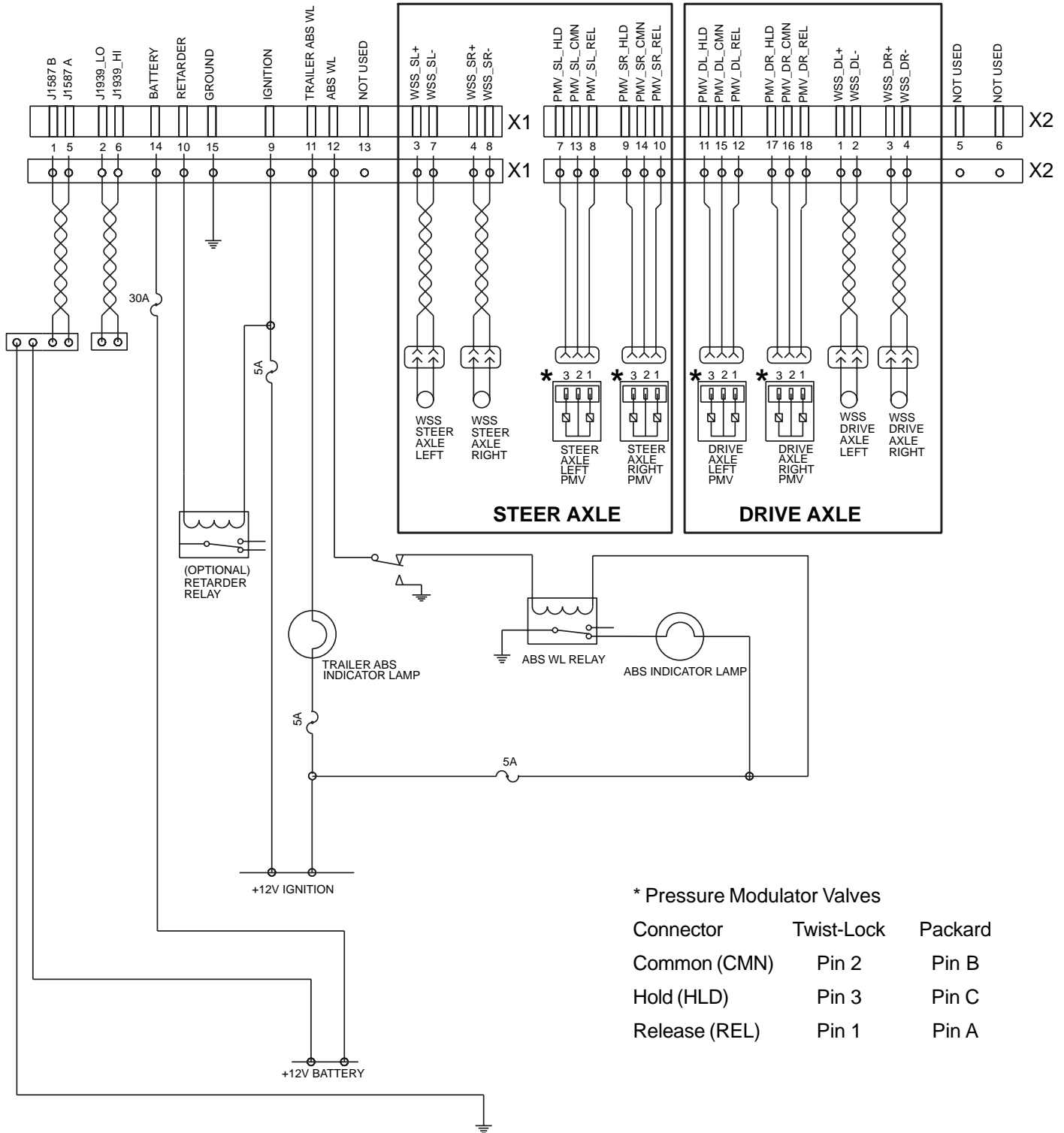
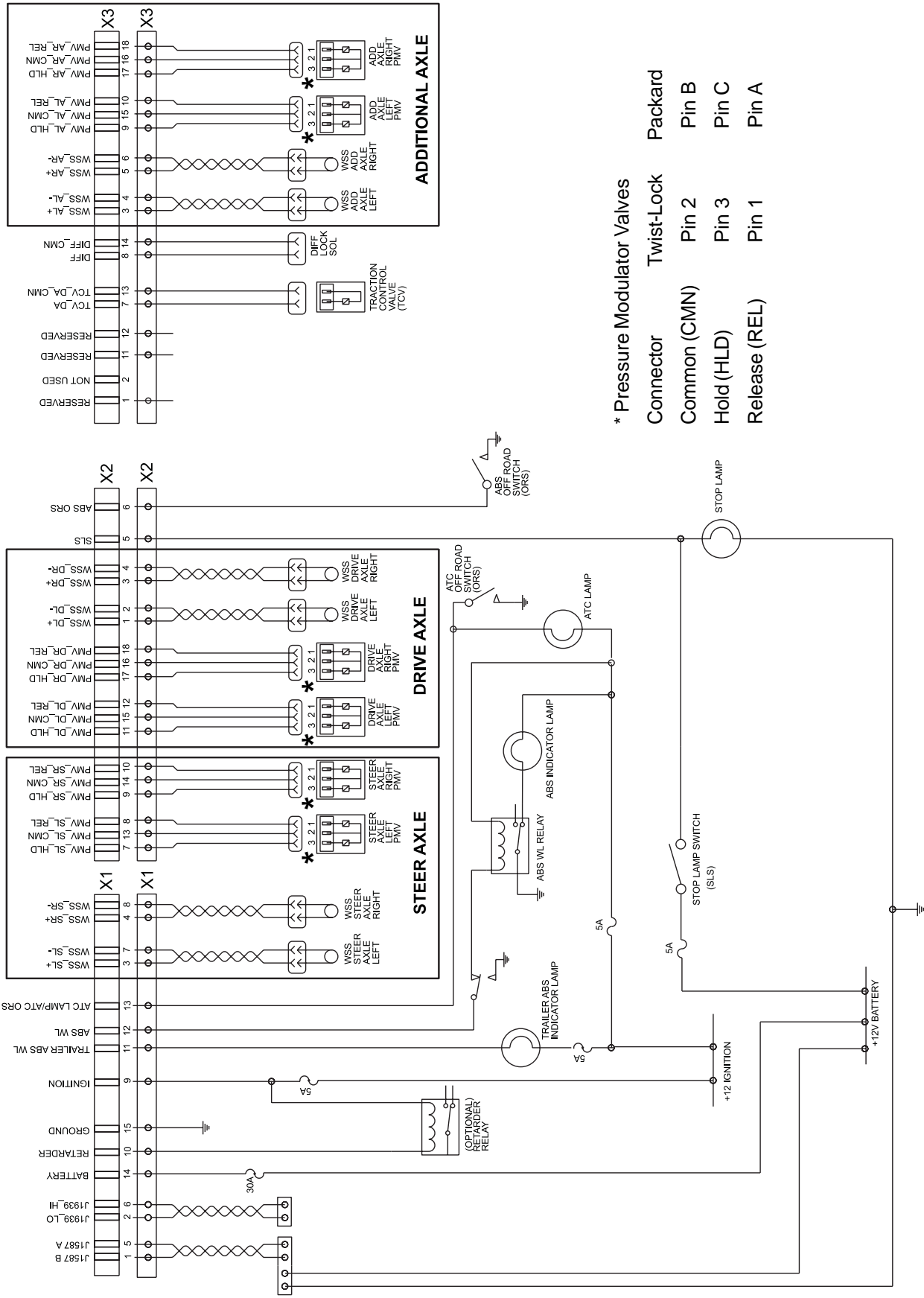

FIGURE 19 - STANDARD FRAME WIRING SCHEMATIC (4S/4M)

Troubleshooting: Premium Frame Wiring Schematic (6S/6M)



* Pressure Modulator Valves

Connector	Twist-Lock	Packard
Common (CMN)	Pin 2	Pin B
Hold (HLD)	Pin 3	Pin C
Release (REL)	Pin 1	Pin A

FIGURE 17 - PREMIUM FRAME WIRING SCHEMATIC (6S/6M)

Troubleshooting: Premium Frame Wiring Schematic (6S/5M)

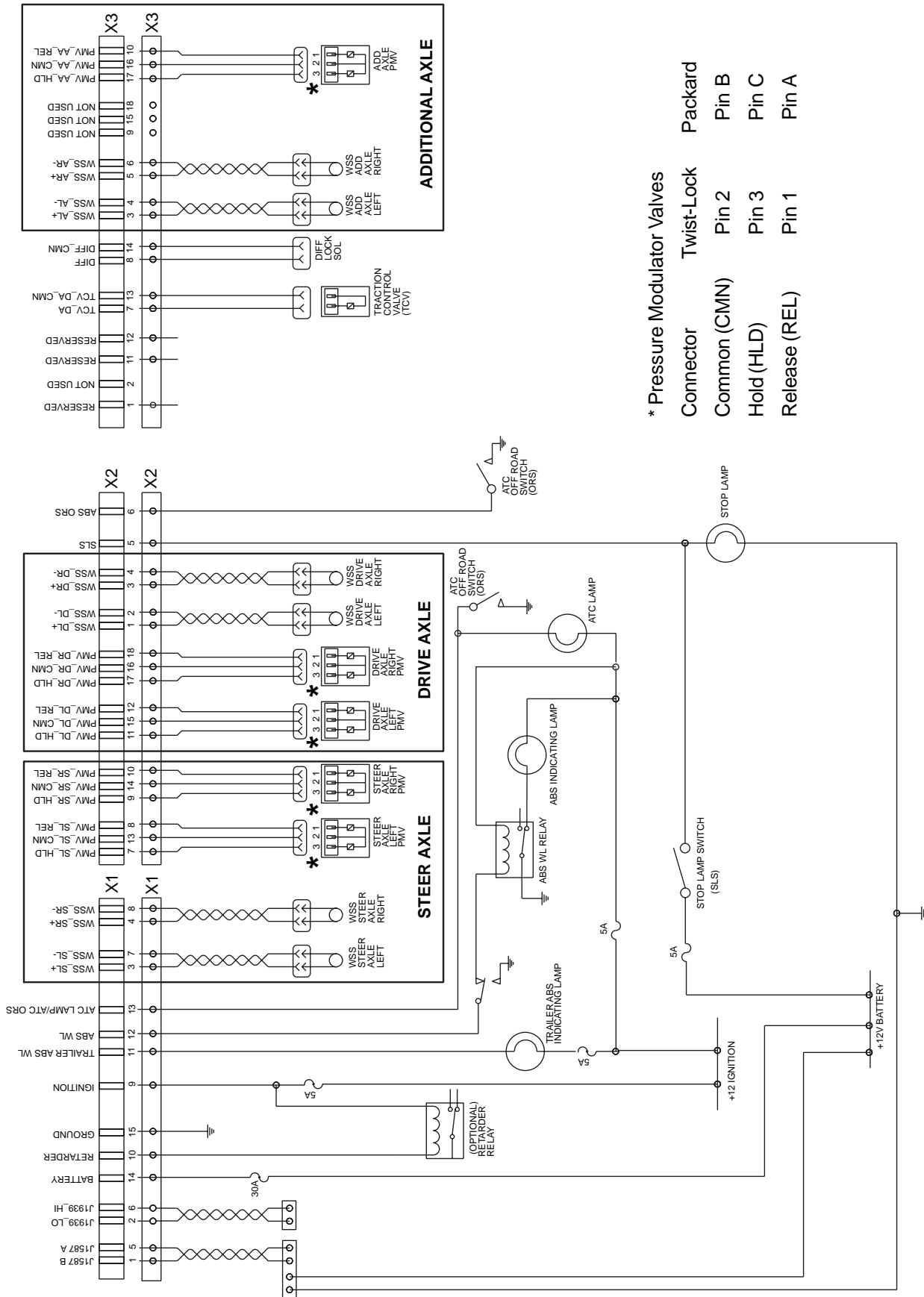

* Pressure Modulator Valves

Connector	Twist-Lock	Packard
Common (CMN)	Pin 2	Pin B
Hold (HLD)	Pin 3	Pin C
Release (REL)	Pin 1	Pin A

FIGURE 21 - PREMIUM FRAME WIRING SCHEMATIC (6S/5M)