

THIS DRAWING IS PROPRIETARY TO TELMA INC. RECEIPT OR POSSESSION CONFERS NO RIGHT TO USE THE SUBJECT MATTER OF THIS DRAWING OR TECHNICAL INFORMATION SHOWN; NOR THE RIGHT TO REPRODUCE THIS DRAWING OR ANY PART EXCEPT FOR THOSE SUPPLIERS OF TELMA INC. WHO RECEIVE A WRITTEN REQUEST FOR MANUFACTURE OR SIMILAR USE.

REVISIONS					
ZONE	LTR	DESCRIPTION	E.C.O.	DATE	APPROVAL

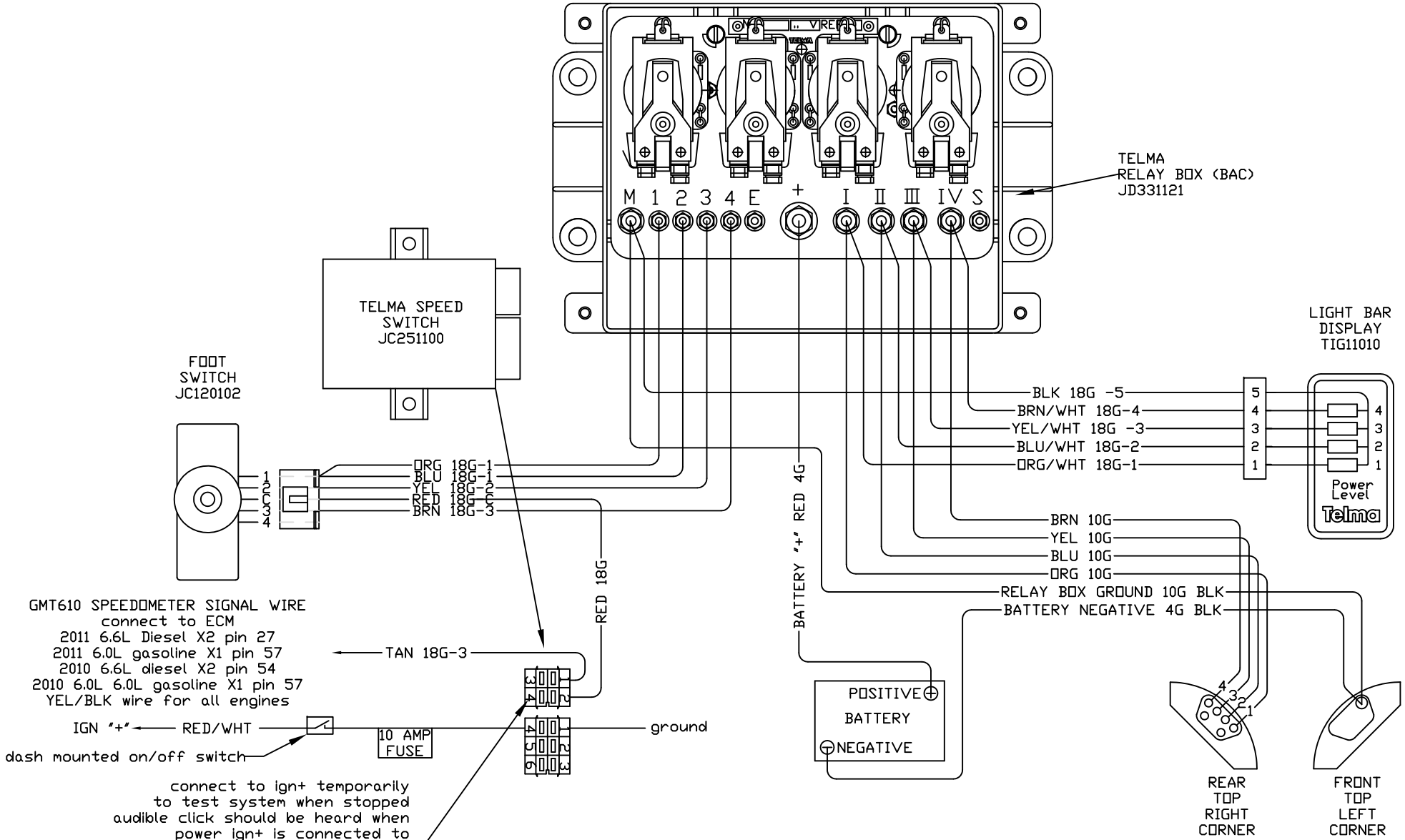

connect to ign+ temporarily to test system when stopped audible click should be heard when power ign+ is connected to pin 4 of the 4-way connector and output #2 of 4-way connector (red wire) should turn on and send ign+ to foot switch common "C" terminal

DRAWN BY:		<p>1821 Morse Avenue Elk Grove Village, IL, U.S.A. (947) 686.0088</p>
CHECKED BY:		
ENGINEER:	HOUSAND	
REVISED BY:		
SUPERSEDES:		
DATE:	1feb11	NAME: CHEVROLET 4500 EXPRESS WIRING WITH SPEED SWITCH
THIS DRAWING WAS PRODUCED IN AUTOCAD AND CAN ONLY BE REVISED IN AUTOCAD. ANY MANUAL CHANGES DONE TO THIS DRAWING WILL BE IGNORED UNLESS AUTHORIZED.		REV: DRWG. NUMBER: TL114035
SCALE:	NTS	SHEET: 1 OF 1