



TL103024

UNIVERSAL

WIRING

PROCEDURE

TABLE OF CONTENTS

1 Control Kits

- 1.1. TIK10100 Universal Manual “Hand” Control
- 1.2. TIK10103 Universal Automatic “Foot” Control for Hydraulic Brakes
- 1.3. TIK10104 Universal Automatic “Foot” Control for Air Brakes

2. Kit Components

- 2.1. Relay Box with Harness
- 2.2. Telma Control Module (TRCM) and Foot Control Cab Harness
- 2.3. Transducer TIG31065 and Transducer Harness TID11051 (air brakes only)
- 2.4. Telma Foot Switch JC120102 and hardware (hydraulic brakes only)
- 2.5. Light Bar Installation

3. Wiring Diagrams

- 3.1. Universal Manual “Hand” Control Wiring Diagram
- 3.2. Universal Automatic “Foot” Control for Hydraulic Brakes
- 3.3. Universal Automatic “Foot” Control for Air Brakes

4. Installation Procedure

- 4.1. Relay Box Installation (all applications)
- 4.2. Wiring Connections to the Telma (all applications)
- 4.3. Connections to the battery (all applications)
- 4.4. TRCM and cab harness Installation (foot control only)
- 4.5. Transducer Installation (air brake foot control only)
- 4.6. Foot Switch Installation (hydraulic brake foot control only)
- 4.7. Light Bar Installation (all applications)
- 4.8. Relay box Control Harness and Light Bar Wiring (all applications)
- 4.9. Hand Control Switch Installation
- 4.10. Foot Switch JC120102 Connector Installation (hydraulic brake foot control only)
- 4.11. Vehicle Wiring Connections

5. Telma Control Module (TRCM) Configuration (foot control only)

- 5.1. Install Telma Desktop Client
- 5.2. Connect the computer to the TRCM
- 5.3. Open Telma Desktop Client
- 5.4. Check COM port (if data status icon is )
- 5.5. Configure TRCM
- 5.6. Test System (foot control only - when vehicle is stopped)
- 5.7. Road Test for Proper Operation

6. Recommended Tools

SECTION 1 CONTROL KITS
1.1 TIK10100 Universal Hand Control

PART NUMBER	DESCRIPTION	QUANTITY
JL210304	HAND CONTROL SWITCH	1
TIB01017	RELAY BOX BRACKET	2
TID11010	HAND CONTROL HARNESS WITH RELAY BOX	1
TIL08002	CAUTION LABEL-MANUAL CONTROL	1
TIG31038	10 AMP FUSE	1
TIG31037	FUSE HOLDER	1
TIG11010	TELMA LIGHT BAR DISPLAY	1
TIF05010	LOCKWASHER 5/16" RELAY BOX MOUNTING	4
TIF05011	NUT 5/16" RELAY BOX MOUNTING	4
TIF05012	HEX BOLT 5/16-18UNCx1 1/4" RELAY BOX BRACKET	4
TIF05013	HEX BOLT 1/2-13UNCx1 1/4" RELAY BOX BRACKET	2
TIF05014	LOCK WASHER 1/2" RELAY BOX BRACKET	2

1.2 TIK10103 Universal Automatic Foot Control for Hydraulic Brakes

PART NUMBER	DESCRIPTION	QUANTITY
JC120102	FOOT CONTROL SWITCH	1
TIB01017	RELAY BOX BRACKET	2
TID11052	HYDRAULIC BRAKE HARNESS WITH RELAY BOX	1
TIG31062	TELMA CONTROL MODULE (TRCM)	1
TIG11010	TELMA LIGHT BAR DISPLAY	1
TIF01063	HEX BOLT 1/4-28UNF x1	2
TIF05000	LOCK WASHER 1/4 SPLIT PEDAL CLAMP	2
TIF05002	NUT 3/8-16UNC HEX G5	2
TIF05003	LOCK WASHER 3/8 G5	1
TIF05004	NUT 1/4-28UNF G8 (USED FOR PEDAL CLAMP)	2
TIF05010	LOCKWASHER 5/16" RELAY BOX MOUNTING	4
TIF05011	NUT 5/16" RELAY BOX MOUNTING	4
TIF05012	HEX BOLT 5/16-18UNCx1 1/4" RELAY BOX BRACKET	4
TIF05013	HEX BOLT 1/2-13UNCx1 1/4" RELAY BOX BRACKET	2
TIF05014	LOCK WASHER 1/2" RELAY BOX BRACKET	2
TIF05019	ELEVATOR BOLT 3/8 16UNC 2.5 INCH	1
TIF05021	RETURN SPRING	1

1.3 TIK10104 Universal Automatic Foot Control for Air Brakes

PART NUMBER	DESCRIPTION	QUANTITY
TIB01017	RELAY BOX BRACKET	2
TID11051	UNIVERSAL TRANSDUCER HARNESS	1
TID11052	AIR BRAKE HARNESS WITH RELAY BOX	1
TIG11010	TELMA LIGHT BAR DISPLAY	1
TIG31062	TELMA CONTROL MODULE (TRCM)	1
TIG31065	MLH PRESSURE TRANSDUCER	1
TIF05010	LOCKWASHER 5/16" RELAY BOX MOUNTING	4
TIF05011	NUT 5/16" RELAY BOX MOUNTING	4
TIF05012	HEX BOLT 5/16-18UNCx1 1/4" RELAY BOX BRACKET	4
TIF05013	HEX BOLT 1/2-13UNCx1 1/4" RELAY BOX BRACKET	2
TIF05014	LOCK WASHER 1/2" RELAY BOX BRACKET	2

SECTION 2 KIT COMPONENTS

2.1 Relay Box with Harness
Included in all kits

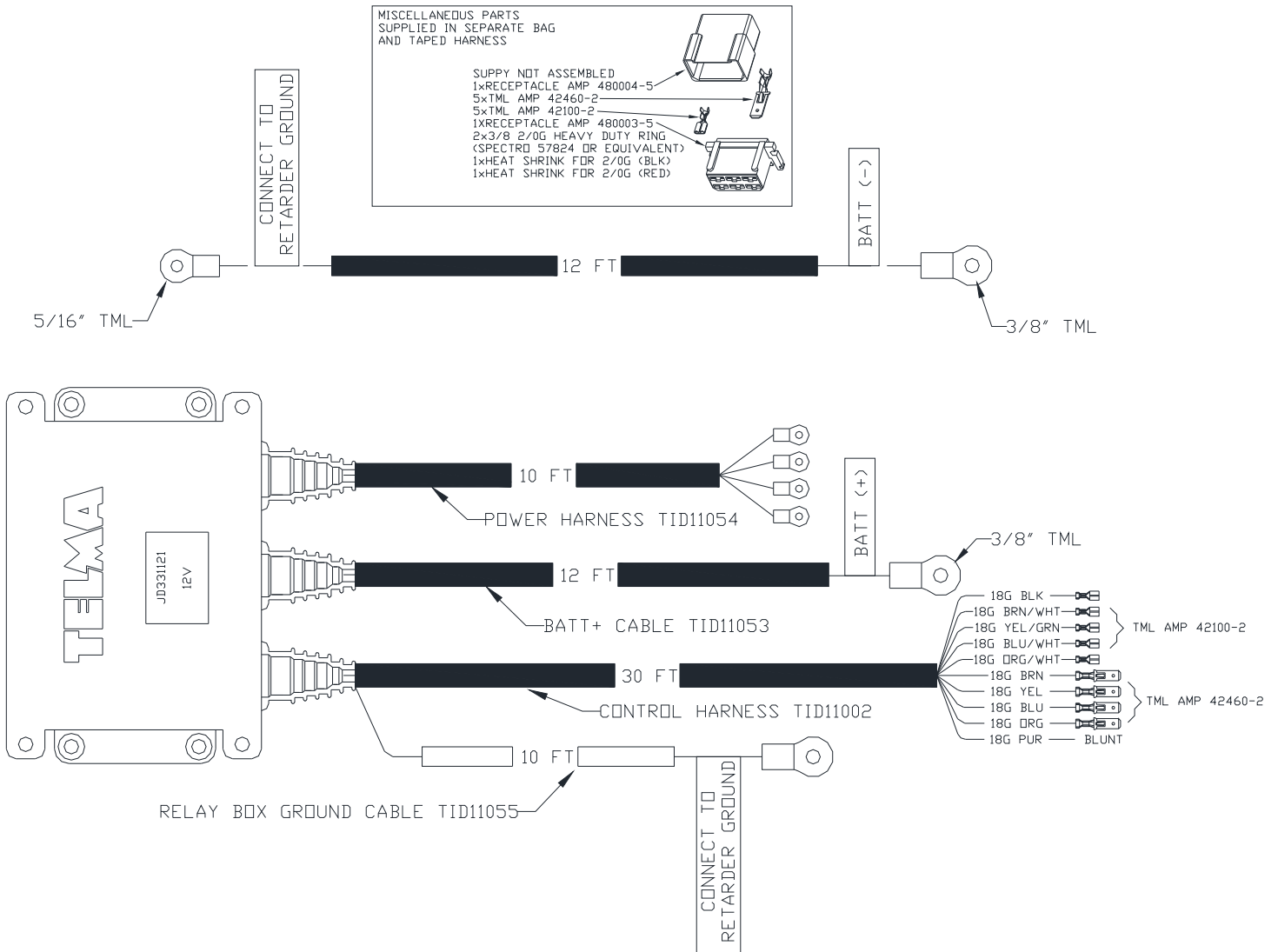

2.2 Telma Control Module (TRCM) and Foot Control Cab Harness

Included in Foot Control kits TIK10103 and TIK10104

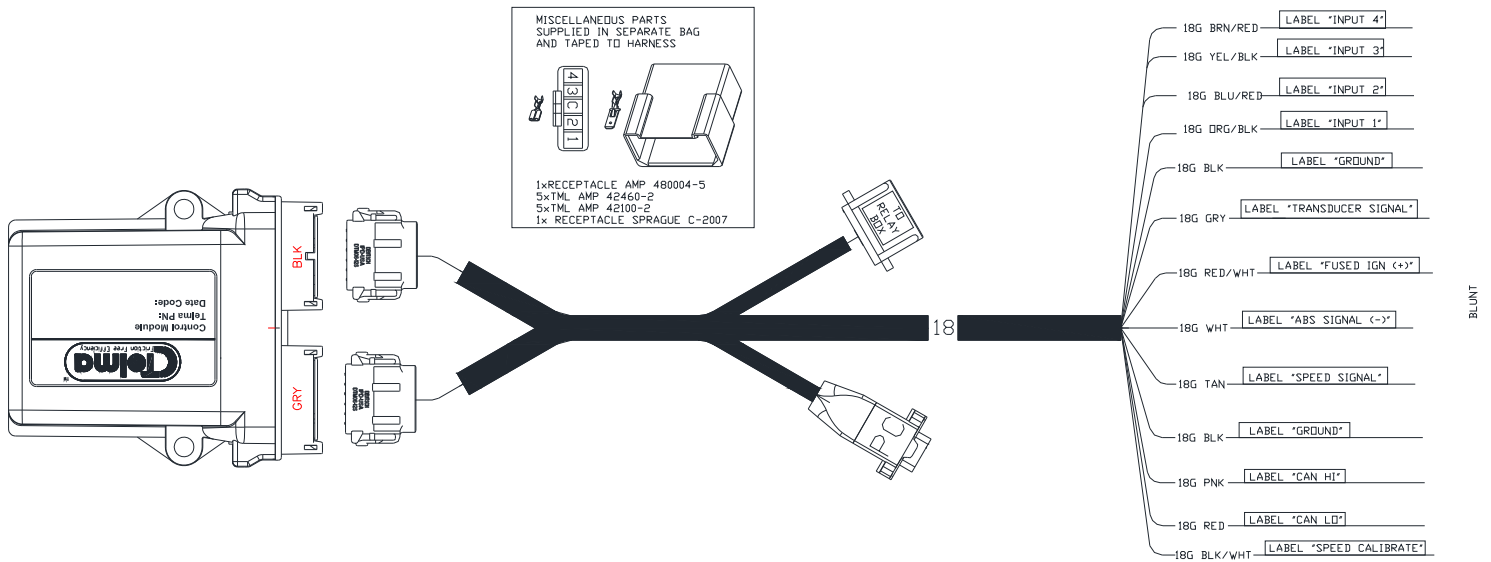

2.3 Transducer TIG31065 and Transducer Harness TID11051 (air brake foot control only)

Included in air foot control kit TIK10104

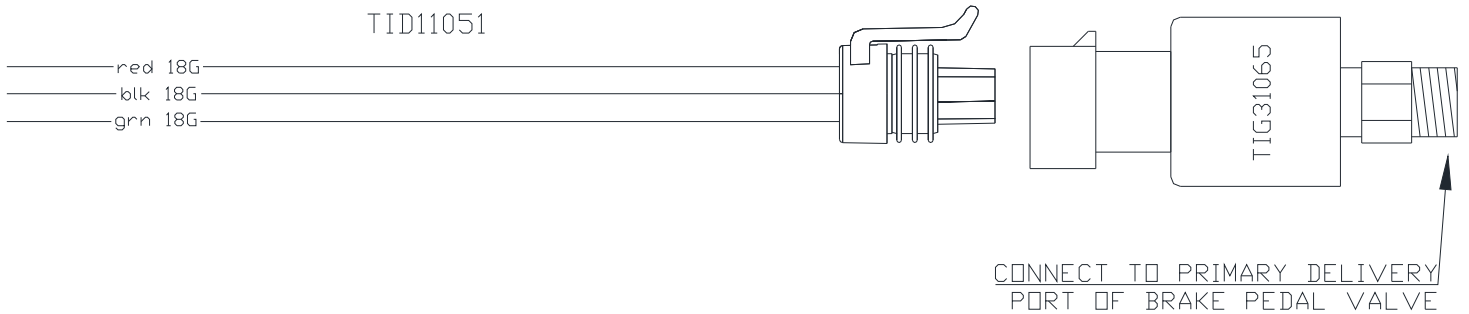

2.4 Telma Foot Switch JC120102 and hardware (hydraulic brake foot control only)
 Included in hydraulic foot control kit TIK10103.

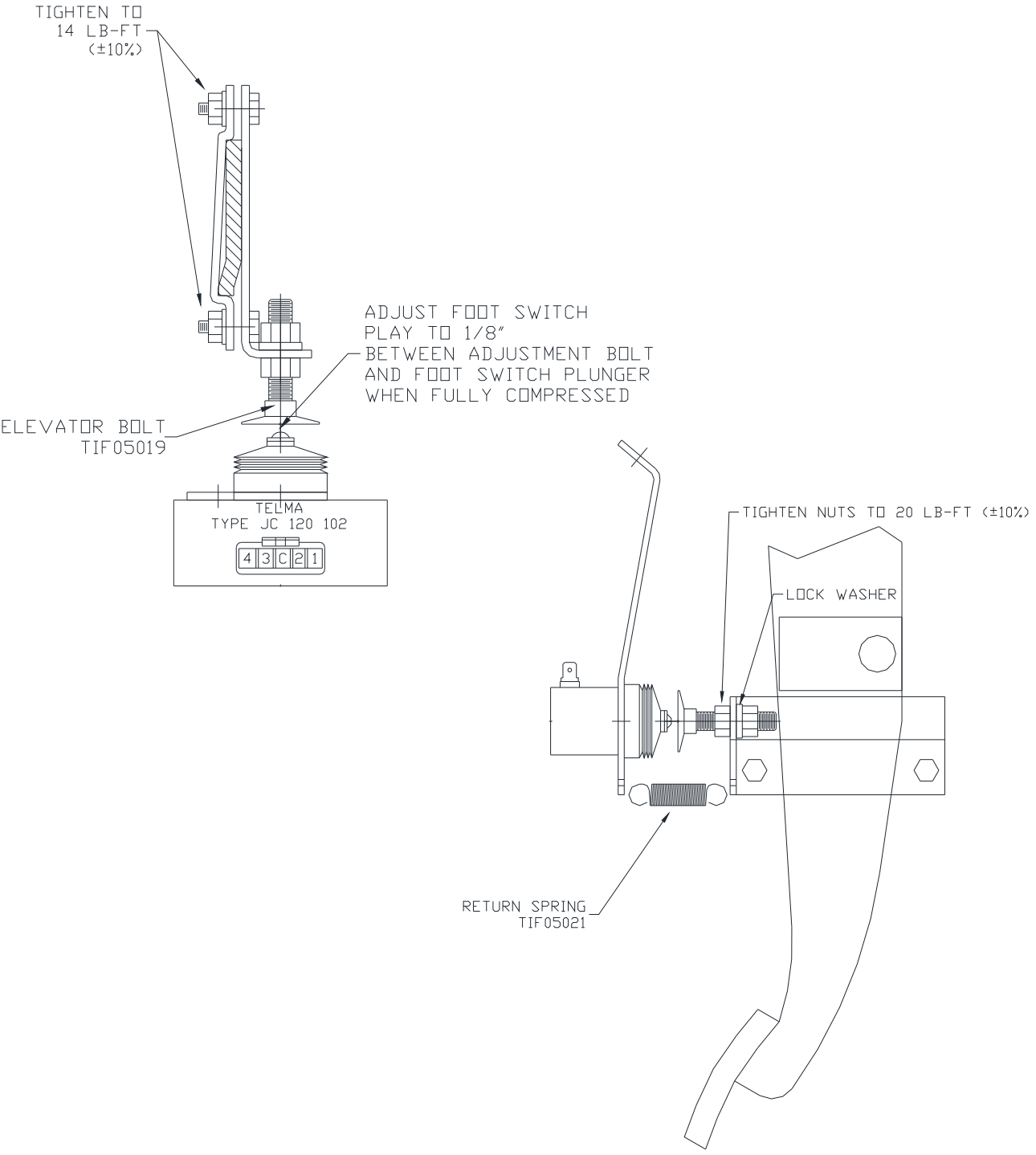

SECTION 3 WIRING DIAGRAMS

3.1 Hand Control Wiring Diagram

TL134051
HAND CONTROL
WIRING DIAGRAM
14oct11jh

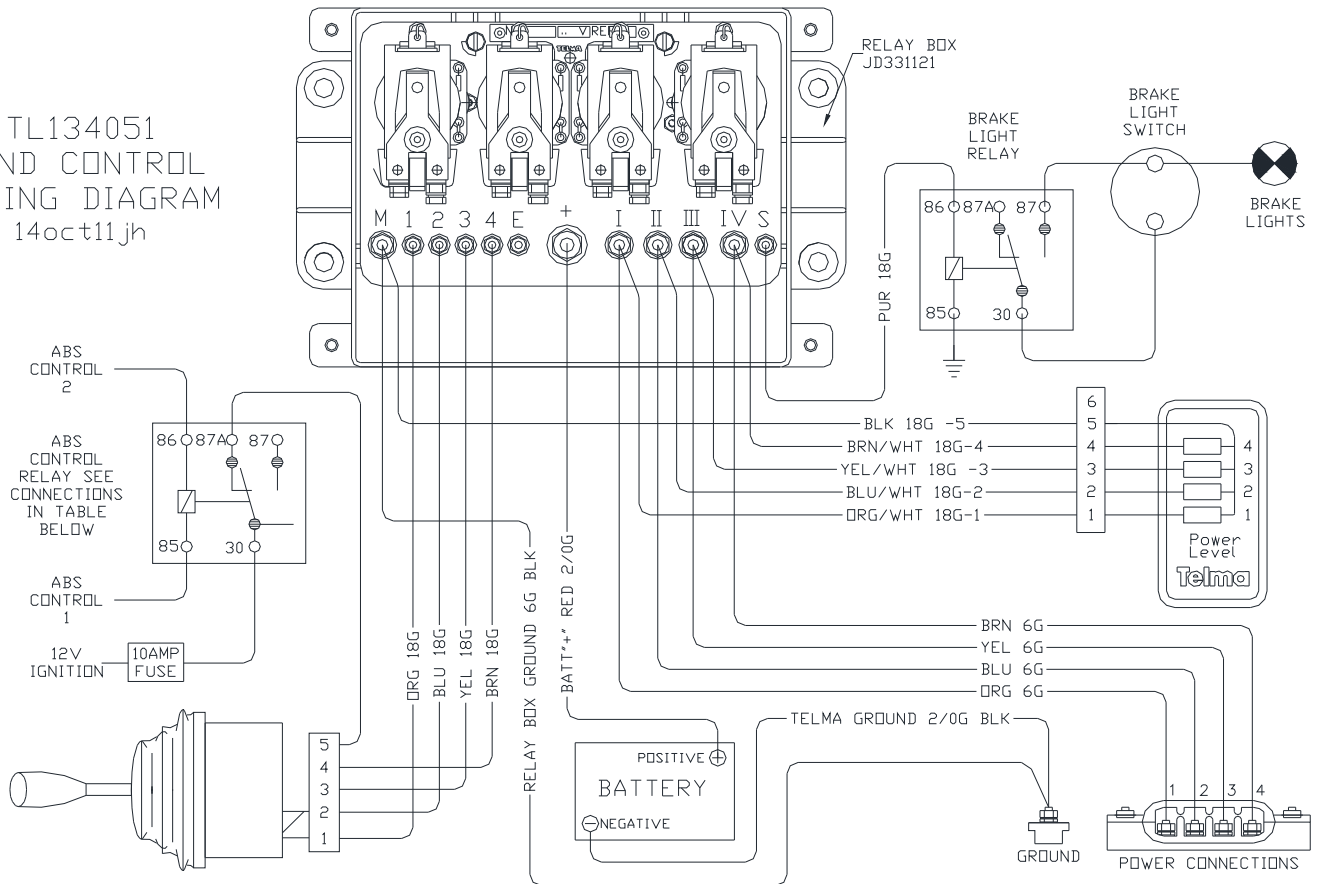

ABS TYPE	ABS CONTROL 1	ABS CONTROL 2
WABCO E CAB AIR	ECU X1 CONNECTOR PIN 14	ECU X1 CONNECTOR PIN 7 (ECU ign+)
BENDIX EC60 FRAME AIR	ECU X1 CONNECTOR PIN 10	ECU X1 CONNECTOR PIN 9 (ECU ign+)
BENDIX EC60 CAB AIR	ECU X1 CONNECTOR PIN 17	ECU X1 CONNECTOR PIN 3 (ECU ign+)
WABCO CAB AIR D BASIC & E	ECU PIN 14 OF 15-PIN CONNECTOR	+12V
WABCO D CAB AIR STANDARD	ECU PIN 17 OF 18-PIN CONNECTOR	ECU PIN 18 (ign+) OF 18-PIN CONNECTOR
WABCO D&E FRAME AIR	ECU PIN 5 OF X1 GRAY CONNECTOR	ECU PIN 2 - X1 GRAY CONN. (ECU ign+)
WABCO D FRAME HYDR	GROUND	ECU PIN 7 OF X2 BLACK CONNECTOR
WABCO D CAB HYDR	GROUND	ECU PIN 12 OF 15-PIN CONNECTOR
TRW HYDR	ECU PIN 2	+12V
BOSSCH 089-0041 HYDR	GROUND	ECU PIN 17
WABCO E HYD	ECU PIN2	ECU PIN 1

3.3 Hydraulic Brake Foot Control Wiring Diagram

TL134055
HYD BRAKE WIRING
DIAGRAM WITH TRCM
AND NO CAN 27oct11jh

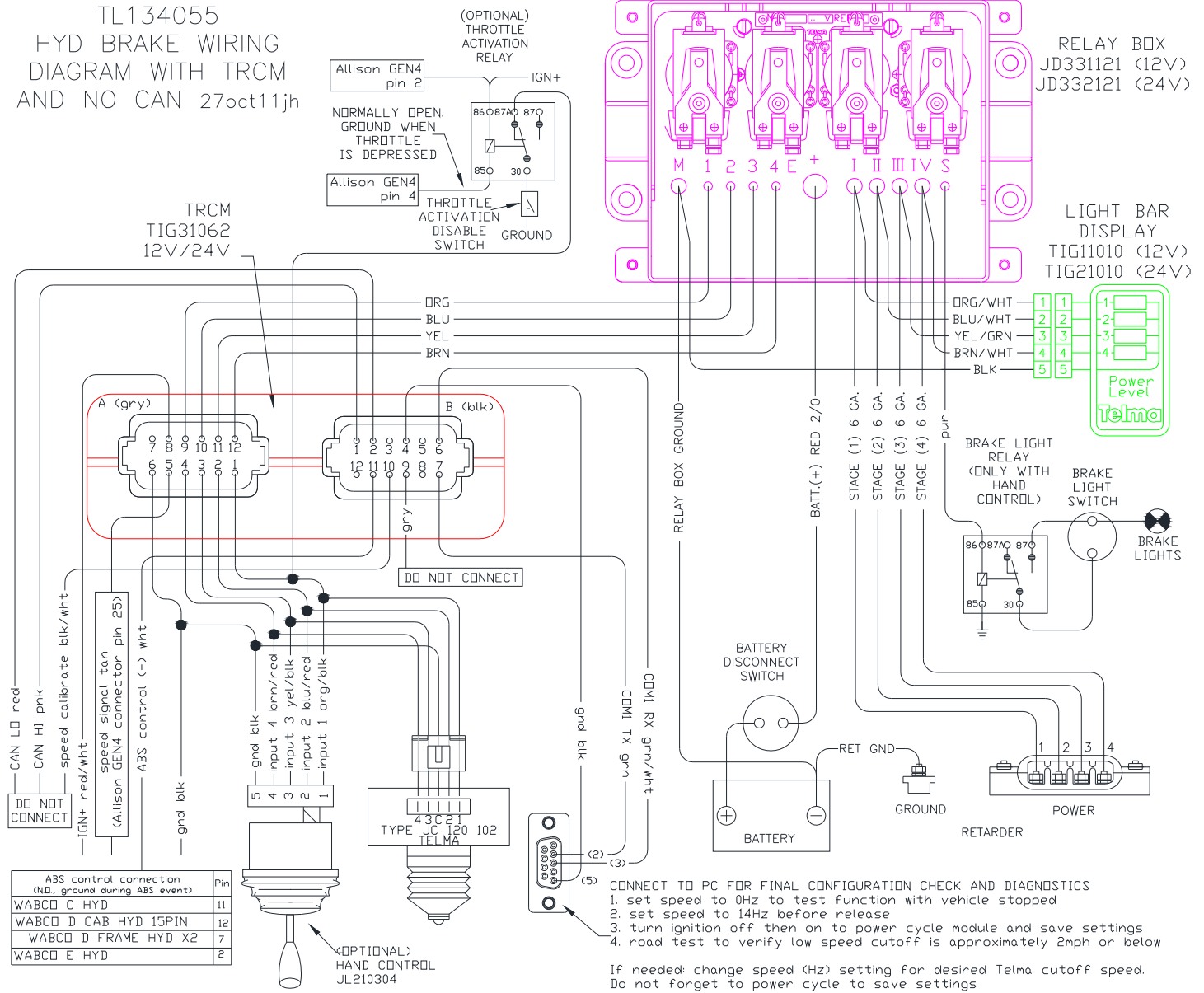

SECTION 4 WIRING HARNESS INSTALLATION PROCEDURE

4.1. Relay Box Installation (all applications)

Mount the relay box on the inside of the frame rail using the brackets TIB01017 or mount directly to the outside of the frame rail. Position the box between the retarder and the batteries with the wiring facing down. Placement should allow easy access to remove the cover of the box for servicing. If installing on a bare chassis, make sure that placement will not interfere with access after body is installed (e.g. outside of frame rail behind compartment). Do not install below water outlets (fire trucks), near heat sources (exhaust), or in wheel wells (road contamination). Make sure the cables reach the batteries and retarder before mounting the box.

4.2. Retarder Wiring Connections (all applications)

Route the wiring along the frame rail to the Telma and across the middle of the Telma to the connecting block as far as possible from the rotors. The connecting block is marked 1,2,3,4 for the four stages of the Telma. Connect the four 6G wires labeled 1,2,3,4 to the appropriate terminals of the connecting block. Connect the 5th 6G relay box ground wire and the 2/0G main retarder ground cable to the Telma ground post. Never allow wiring to pass across the rotors where heat from the rotors will damage the wiring. For axial (chassis mount) retarders clamp the harness to the retarder bracket. Use a rubber coated metal cable clamp. For a focal (differential mount) retarder use harness bracket kit TIK00106 for single axles or TIK00107 for tandem axles. Refer to service bulletins TIL00105 (TIK00106) or TIL15006 (TIK00107) for proper harness routing and securing. Make sure there is enough length after the clamp to allow for movement of the axle.

4.3. Battery Wiring Connections (all applications)

Route the battery power cable from the relay box along the inside of the frame rail to the positive side of the battery pack. If practical it is preferable to connect to a remote battery positive connection stud or the starter terminal instead of directly to the positive terminal of the battery, which can be a point of corrosion. Remote mounting also reduces the amount of cables connected to the battery terminal. The positive cable can also be connected to the chassis side of the battery disconnect switch if the switch is rated for the amperage needed for the retarder + vehicle loads. Refer to service bulletin TIL35027 for more details about connecting to the battery disconnect switch.

Route the retarder ground cable from the retarder ground point to the negative side of the battery pack. As with the positive cable it is preferable to connect to a remote battery negative connection point or to the starter ground terminal instead of directly to the negative terminal of the battery. The ground cable may be connected to the chassis frame only if the main battery pack ground is connected to the chassis frame with at least a 2/0 cable.

4.4. Telma Control Module (TRCM) and cab harness Installation (foot control only)

Attach the cab harness to the TRCM. Find a suitable place in the cab to mount the TRCM and harness assembly that is out of the way yet accessible for servicing. Secure the TRCM using fasteners in the mounting holes. Do not secure with wire ties or leave unsecured. Make sure the vehicle wiring connections of the cab harness reaches the connections in the cab for ignition "+", the speed signal and ABS wiring.

4.5. Transducer Installation (air brake foot control only)

Install the transducer directly or on a manifold or 1/4" air line connected to the primary delivery port of the brake pedal valve. Plug the transducer harness TID11051 onto the transducer. Connect the black wire to ground, the red wire to ignition +, and the green wire to the gray wire of the Telma cab harness.

4.6. Foot Switch JC120102 Installation (hydraulic brake foot control only)

Mount the foot switch under the dash with a bracket along with brackets on the pedal. Switch and pedal brackets for some applications are available from Telma. For other applications, brackets must be fabricated for the installation. Contact Telma for more information.

The plunger type foot switch should be carefully adjusted to avoid switch damage and optimize retarder activation in the free play of the pedal. With the return spring installed, use a feeler gauge and adjust the switch stop (item 5) until there is 1/8" gap. The switch plunger should be fully compressed and the brake pedal should be in its highest position.

ITEM	DESCRIPTION
1	3/8" lock washer
2	Pedal bracket
3	foot switch JC120102
4	feeler gauge
5	3/8" diameter switch stop adjusting bolt
6	3/8" jam nuts

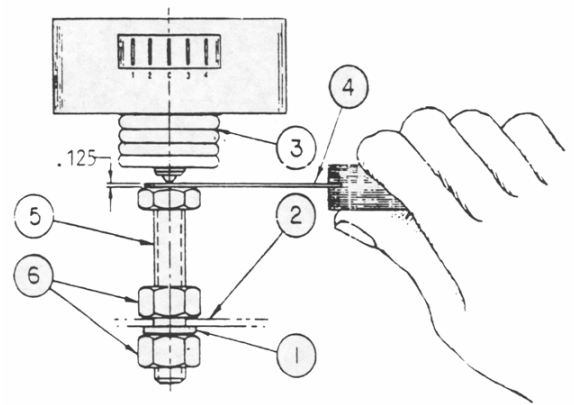

4.7. Light Bar Display (all applications)

Find an empty switch blank in the dash to mount the light bar display if available. The display is designed to fit the full size euro-look switch blank. If there is no blank available a rectangular hole will need to be cut. See service bulletin TIL15001 for details. The display should be easily visible to the driver when installed.

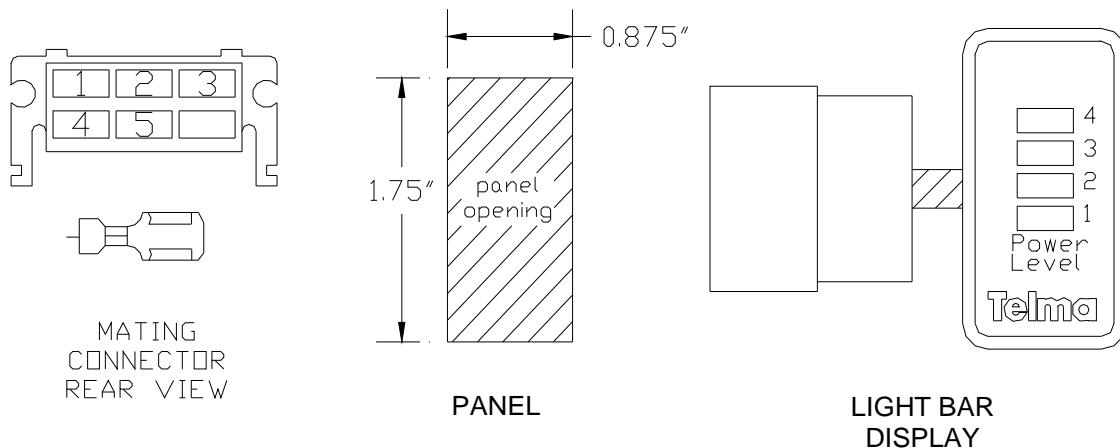

4.8. Relay Box Control Harness and Light Bar Wiring (all applications)

Route the relay box control harness (1/2" loom with 10 18G wires) from the relay box along the inside of the frame rail and into the cab (through an existing hole if possible). Inside the cab, open the loom and split the wires into two groups. If necessary cut these two groups of wires to the best lengths needed to reach the cab harness connector (or hand control switch) and light bar display when installed. If the harness is shortened it will be necessary to install new wire terminals (included in the kit). The orange, blue, yellow, and brown wires connect to the cab harness labeled "relay box" or to the hand control switch (hand control only applications). For foot control, find the white female receptacle taped to the harness (and 4 male terminals if needed) and install into the receptacle (orange-1, blu-2, yellow-3, brown-4). For the connection to the light bar find the white male receptacle (and five female terminals if needed) included with the light bar display and install onto the group of wires (orange/white-1, blue/white-2, yellow/green-3, brown/white-4, black-5). Plug the light bar harness into the light bar.

4.9. Hand Control Switch JL210304 Installation (hand control and optional dual control)

Find a suitable place to mount the switch on the column or in the dash so that it is accessible to the driver. For systems without foot control connect the relay box control wiring directly to the hand control switch using the mating receptacle and terminals supplied with the hand control switch (orange-1, blue-2, yellow-3, brown-4, fused ignition "+" position 5). Consult Telma technical information if optional low speed cut-off and throttle active disable are required. If a hand control will be added to foot control for combined or (dual) control, a 5 wire harness will need to be made up to go from the hand control switch to the cab harness. At the hand control switch connect using the mating receptacle and terminals supplied with the hand control switch. If possible use the wire colors (org/blk-1, blu/red-2, yel/blk-3, brn/red-4, and black-5). At the TRCM cab harness connect to the wires (org/blk "input1", blu/red "input2", yel/blk "input3", brn/red "input4", blk "ground").

4.10. Foot Switch JC120102 Connector Installation (hydraulic brake foot control only)

Find the foot switch connector and terminals supplied in the kit and crimp the terminals on the wires of the TRCM cab harness (orange – org/blk "input1", blu/red "input2", yel/blk "input3", brn/red "input4", blk "ground") using a proper crimp tool designed for non-insulated terminals. Install the terminals into the foot switch connector (org/blk-1, blu/red-2, blk-3, yel/blk-4, brn/red-5). Plug the connector onto the foot switch making sure that position 1 (org/blk wire) lines up with position 1 marked on the foot switch JC120102. If a hand control will be added to foot control for combined or (dual) control, a 5 wire harness will need to be made up to go from the hand control switch to the cab harness. At the hand control switch connect using the mating receptacle and terminals supplied with the hand control switch. If possible use the wire colors (org/blk-1, blu/red-2, yel/blk-3, brn/red-4, and black-5). At the foot switch connector splice to the wires installed into the connector (org/blk-1, blu/red-2, blk-3, yel/blk-4, brn/red-5).

4.11. Vehicle Wiring Connections (ign+, ABS control, speed signal for foot control)

Connect the following wires of the TRCM cab harness to the vehicle

- red/wht wire to a fused ignition source.
- white wire to the ABS module retarder control pin as indicated on the wiring diagram
- tan wire to the speed signal source (e.g. Allison GEN 4 pin 25)

SECTION 5 Telma Control Module (TRCM) Configuration (foot control only)

After the Telma system is installed, the TRCM must be configured using the Telma Desktop Client and a cable connected from your computer to the TRCM installed on the vehicle. This interface can also be used to diagnose and troubleshoot the Telma Control System.

5.1. Install Telma Desktop Client

Download the [Telma Desktop Client](#) from the telmausa.com website and install the software on the computer that you will be using to connect to the TRCM. The software will only work on computers with the Microsoft Windows XP or newer operating system. Unzip the file to a folder and double click the file TelmaDesktop.....exe to install the Telma Desktop Client on your computer. You also may need to update Microsoft dotNet on your computer. The file to update Microsoft dotNet is also included in the ZIP file.

5.2. Connect the computer to the TRCM

Connect the computer to the DB9 serial connector of the Telma cab harness . Use a straight through serial cable (not a null modem cable). If your computer does not have a DB9 serial connector you will need to use a USB-to-serial adapter. All USB-to-serial adapters do not work. It is recommended that you purchase a USB-to-serial adapter from Telma, part number TIG01027 which has been tested to work correctly. IO Gear GUC232A has also been tested to work correctly and should be available online or from your local office supply or electronics store.

5.3. Open Telma Desktop Client

- Switch on the vehicle ignition
- Open the Telma Desktop Client.
- Click on the start button in the Telma Configuration window and observe if the Data Status icon switches to a green check mark. If the data status has a green check mark this indicates that the module is communicating with the Telma Desktop Client. If this is the case skip step 5.4 and go to step 5.5 after finishing step 5.3. If no green check mark, go to step 5.4 after step 5.3 to troubleshoot the COM port configuration.

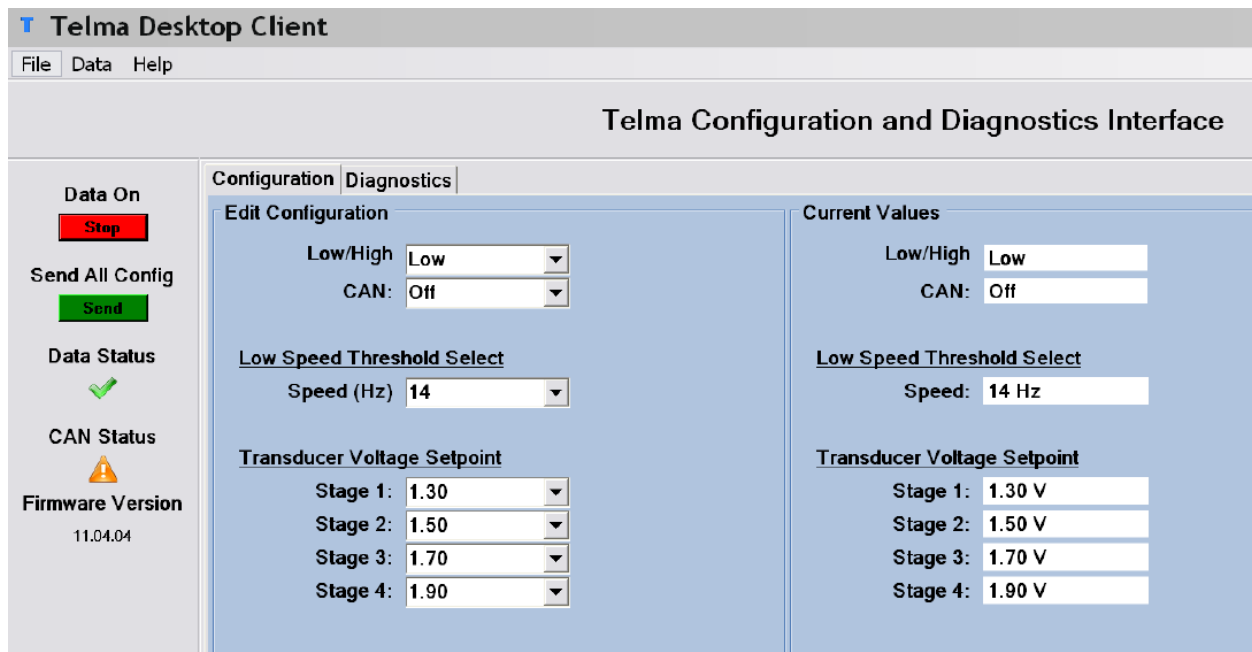

5.4. Check COM port (if data status icon is)

If data status icon is , this indicates there is a problem with communication between the Telma Desktop Client and the TRCM.

- Click file > Configuration in the Telma Desktop Client to check which COM port is assigned.

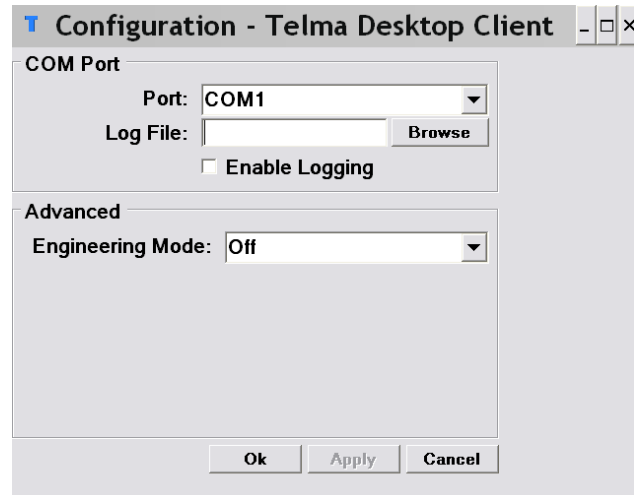
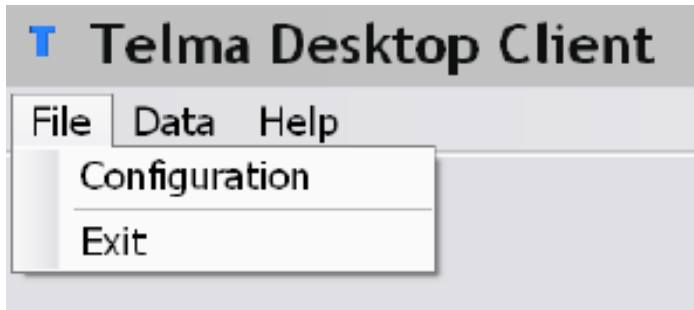

- Open device manager on your computer. Click on START > RUN, type in devmgmt.msc and click OK or press ENTER. Check which COM port is assigned to the serial communications port or USB-to-serial adapter.

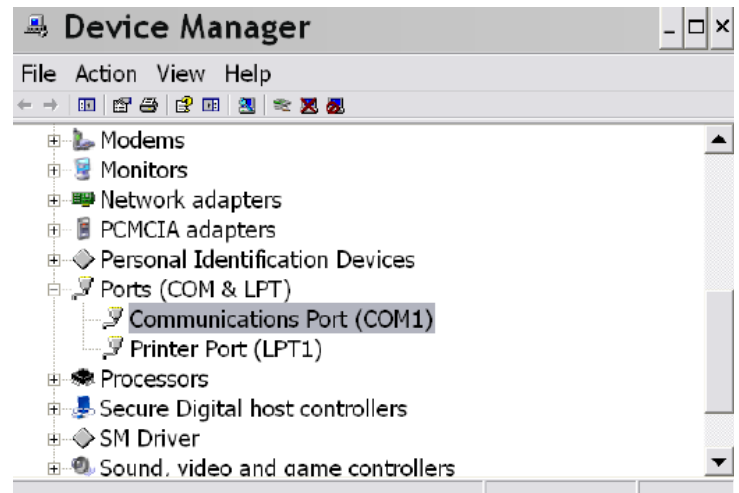
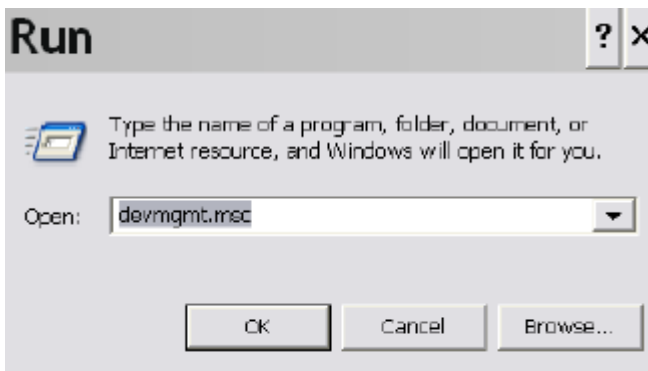

If the COM port numbers are not the same change the COM port number in the Telma Desktop Client to match the Device Manager using the drop down menu in the Telma Desktop Client. If the COM ports are the same but there is no green check mark and you are not using an approved USB-to-serial adapter, obtain an approved USB-to-serial adapter and try again. If you are connected directly to a serial port on the computer, try changing the cable (straight through not null modem cable) and try again. If there is still no communication contact Telma technical support at 800 797-7714 or send us an email to engineering@telmacse.com describing the problem.

5.5. Configure TRCM

Ignition should be turned on and data status should show green check mark before proceeding.

- In the edit configuration menu as shown below make sure the settings are as shown below. Make changes as needed using the drop down menus. The changes you make should immediately show up in the current values menu.
 - Low/Hi = Low
 - CAN = Off
 - Speed (Hz) = 14
 - Transducer voltage Setpoint
 - Stage1 = 1.30 (3psi)
 - Stage 2 = 1.50 (5psi)
 - Stage 3 = 1.70 (7psi)
 - Stage4 = 1.90 (9psi)
- Turn ignition off and then back on to save the configuration changes

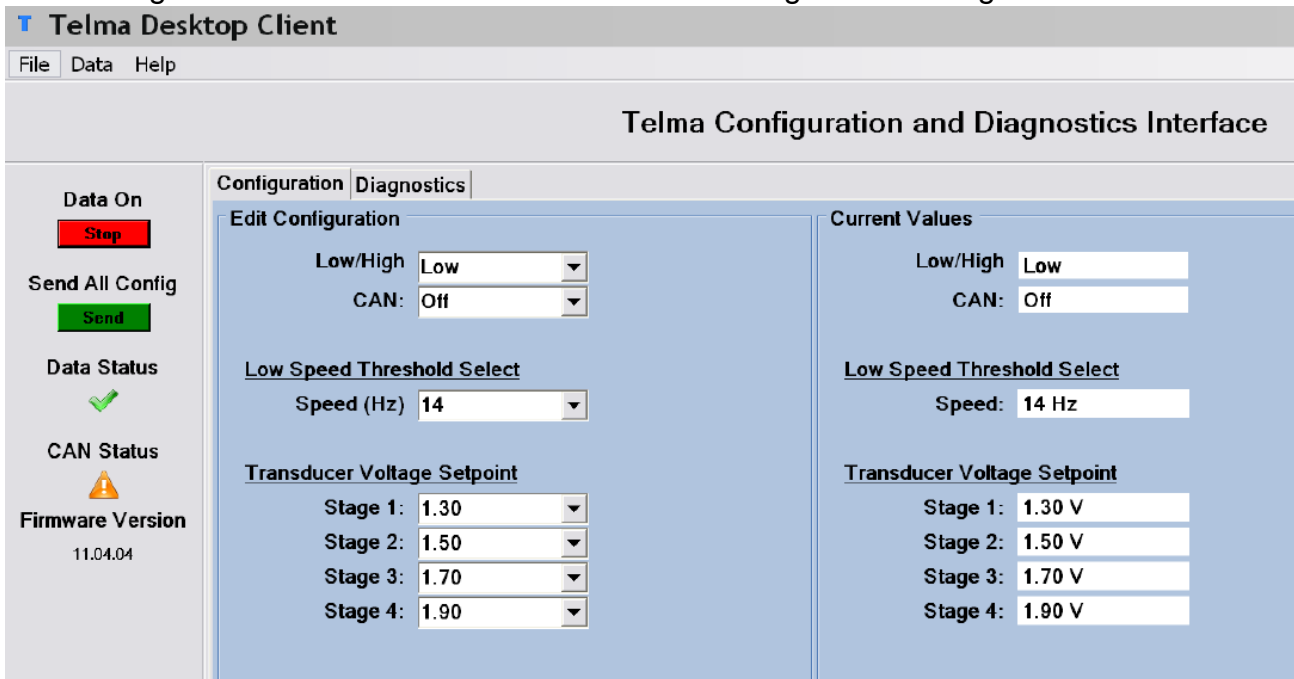

5.6. Test System (foot control only - when vehicle is stopped)

- Set the speed (Hz) to 0 and test Telma system function when vehicle is stopped.
- Reset speed (Hz) to 14.
- Turn ignition off and then on to power cycle module and save settings

5.7. Road Test for Proper Operation

Road test to verify desired system function (transducer settings) and verify that low speed cut-off is approximately 2 mph or below

SECTION 6 RECOMMENDED TOOLS

Common mechanics hand tools

Wiring terminal crimping pliers for non insulated terminals

Computer with serial port or approved USB-to-serial adapter (TIG01027 or IO Gear GUC232A) and DB9 serial cable (straight through, not null modem cable)